

PROFITS MAXIMIZED

Eicher Pro 6018TT

The 34T GCM Tractor Trailer



- VOLVO GROUP ENGINE MANAGEMENT SYSTEM**
- CABIN ADAPTED FROM JAPANESE DESIGN**
- MEETS AIS 029 SAFETY STANDARDS**



PARTNERSHIP WITH THE VOLVO GROUP

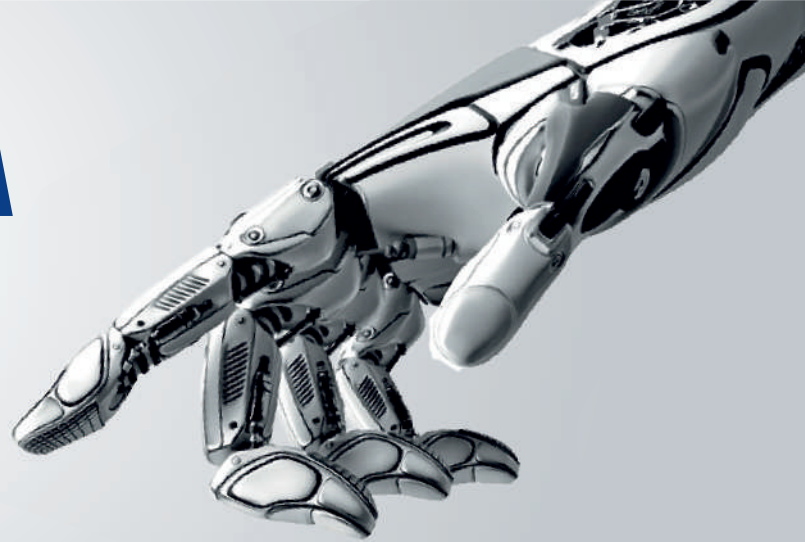
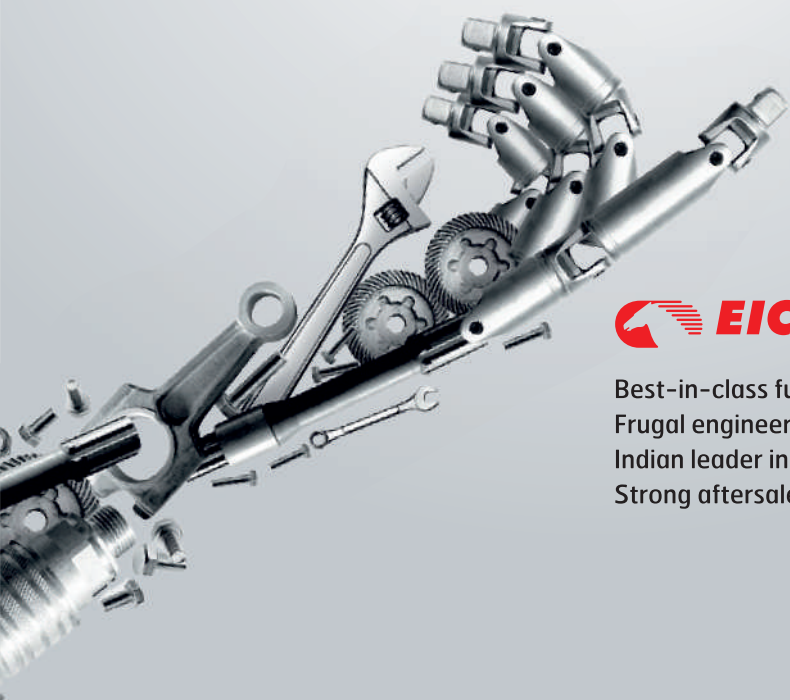

Best-in-class fuel efficiency
Frugal engineering & operations
Indian leader in medium-duty trucks
Strong aftersales support



VOLVO GROUP

Environment & safety conscious
World-class technology
Global leaders in heavy-duty trucks
Customer-driven solutions



MAXIMUM LIFETIME PROFITABILITY WITH PRO 6018TT

The new Eicher Pro 6018TT is a ready-to-use 4x2 tractor trailer with a GCM of 34T. It promises to provide an unparalleled business advantage by maximizing the product performance right from day one of operations and minimizing the cost of acquisition at the same time.

More km per Liter



Superior comfort & Enhanced safety



Superior Uptime



Low cost of ownership



More km per Liter

The new Eicher Pro 6018TT is designed to deliver best-in-class fuel efficiency, thereby reducing the overall operational costs and maximizing profits. The proven VEDX8 engine clubbed with Volvo Group's EMS delivers high peak torque over a wide range of RPM, resulting in more trips with lesser fuel consumption.



Denso FIE System



Volvo Group's EMS



Viscotronic Fan & ESS Compressor



Proven VEDX8 Engine
250hp @ 2200 rpm



HVAC Cabin

Superior comfort & Enhanced safety

The cabin of Pro 6018TT is fashioned keeping in mind the difficult driving conditions and the comfort of the driver for long driving hours. The global cabin ensures better comfort for the drivers and safeguards them by making certain they remain alert for long.



IDIS



Air Suspended Driver Seat



Dual Panel Crash Tested Cabin



FUEL CONSUMPTION METER



WATER IN FUEL SENSOR



AIR FILTER RESTRICTION INDICATOR

Superior Uptime

Uptime is the key requirement when goods need to be transported. Pro 6018TT is designed to deliver superior uptime for seamless functioning and maximizing the performance.



On Board Diagnostic System



4-way Engine Protection System

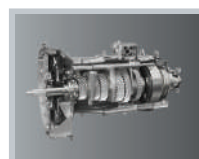

ET140 9-Speed Gearbox



Domex Chassis

TECHNICAL SPECIFICATION

Eicher Pro 6018TT

The 34T GCM Tractor Trailer

Model	Pro 6018TT
Vehicle Weight (Kgs)	
GVM	18500
FAW (laden)	7500
RAW (laden)	1100
GCM	34000
Engine	
Model	VEDX8, 6 cylinder 4 valve per cylinder, turbo charged, intercooled diesel, common rail
Max Power	250 hp @ 2200 rpm
Max Torque	950 Nm @ 1100-1500 rpm
Emission	Euro III
Transmission	
Gear Box	Et140 S9-9-speed transmission
Clutch	
Clutch	430 mm organic clutch with clutch booster
Rear Axle	
Rear Axle Ratio	4.8
Chassis Frame	
Type	Ladder type joggle frame
Section	285 X 76 X 7

Steering System

Type	Power steering
TCR (M)	13.4

Suspension

Front Suspension	Semi-elliptical leaf spring with double acting telescopic shock absorber & anti-roll bar
Rear Suspension	Semi-elliptical laminated leaf spring

Wheels & Tyres

Tyre Size	Tubeless radial 295/80R22.5-16PR
Wheel Rim size	8.25x22.5

Cabin

Type	Sleeper cabin
------	---------------

Brakes

Brake type	Dual circuit, Full Air S-Cam
Parking brake type	Pneumatic control, Rear spring brake actuator

ABS	Yes
-----	-----

Electrical

Battery	24 V, 120 Ah (2 nos.)
---------	-----------------------

Fuel Tank

Size	380 litres
------	------------

Performance

Max Speed (kmph)	93
Gradeability	35%

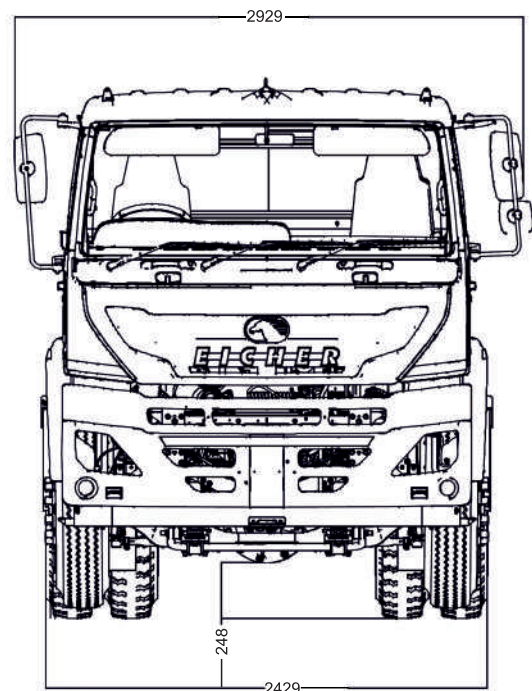
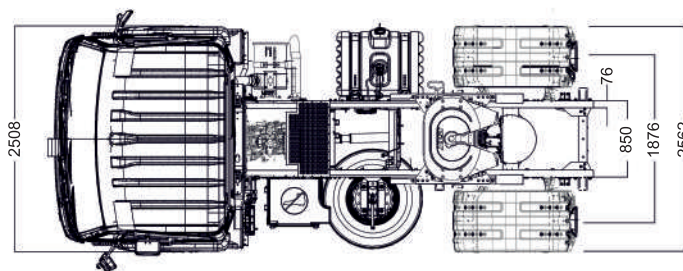
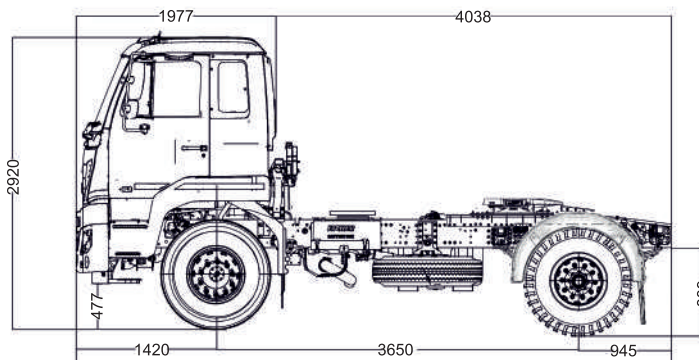

Volvo Group Call Centre (Jet Park) 0800 342 437